



NETWORK CUBE > CWDM-MUX-8+UG Module

C-1678-Rev. C

Product Description

- CWDM over WWDM module for integration in 1 slot of the CUBO NETWORK CUBE WDM-Modular-Shell (C-1608).
 - The module contains 2 pieces of 8 channel CWDM multiplexers (1 mux, 1 demux) and 2 pieces of Bandsplitters (“skip1”)
 - The bandsplitter multiplex, respectively demultiplex the 1310nm from the 1550nm band. The 1550nm port is internally connected to the 8 channel CWDM mux, respectively demux, The 1310nm ports (“Ug”) are available at the front plate as an adapter for a later upgrade to connect a further 8 or 9 channel CWDM module.
 - CWDM multiplexers to mux and demux 8 channels from 1471 to 1611nm; these correspond to the transceiver wavelengths from 1470 to 1610 nm.
 - The CWDM multiplexers are compliant with the ITU G.694.2 standard and Telcordia GR1221 (former Bellcore) standard and are designed to meet NEBS level 3.
 - The sub-system interoperates with any router, switch, DSLAM, SFP and GBIC, which supports the CWDM ITU G.694.2 standard.
 - Front panel is equipped with adapters according to customer choice (see below).
- Product Description: NETWORK CUBE CWDM-MUX-8+UG Module
 - Product Code: C-1678
 - Connector Code: -XY (choose from table below)
 - Revision Level: -Rev.C

Example Order Code: C-1678-15-Rev.C for a module with SC/PC on common / trunk ports, LC/PC on all CWDM channel ports and UG ports.

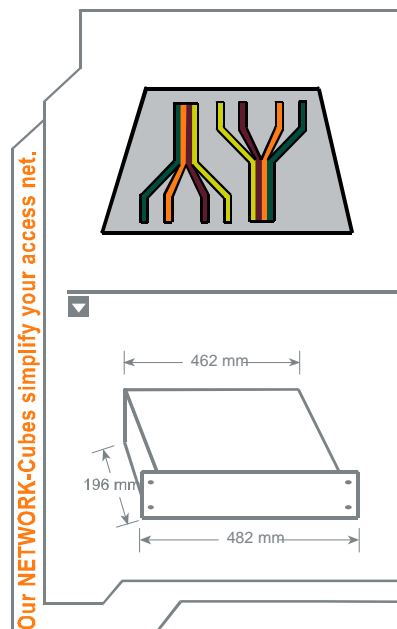

Our NETWORK-Cubes simplify your access net.

(X) Common ports	(Y) CWDM + Ug ports	Code
SC/PC		1
FC/PC		2
SC/APC		3
FC/APC		4
LC/PC		5
MU/PC		6
E2000		7
E2000/HRL		8
ST/PC		9
other		tbd

Revision History

No.	Description	Date	Created by	Approved by
A	Initial release	03.12.05	Sven Krüger	
B	Revised optical data	11.03.06	Thomas Paatzsch	
C	Connector Code changed	01.07.09	Sven Krüger	
C	Included typical insertion loss	22.03.10	Islah Touhtouh	

NETWORK CUBE

> CWDM-MUX-8+UG Module

C-1678-Rev. C

General Specifications

Operating Temperature	+0°C to +70°C	
Storage Temperature	-40°C to +80°C	
Max. optical Power	< 250 mW	
Package Dimensions	Width: 166 / 182 mm, Height: 25.75 / 44 mm, Depth: 118.5 / 125.2 mm	
Fiber Type	SMF-28 compatible Ø 9 / 125 / 250µm	
Optical Adapters	as defined by customer via order code	

Optical Performance of each of the 2 Multiplexers (1 mux, 1 demux, incl. Ug)

Operating Channels		
CWDM ports [nm]	C1=1471 C2=1491 C3=1511 C4=1531 C5=1551 C6=1571 C7=1591 C8=1611	
Upgrade ports	Ug = 1271 - 1431 nm	
Channel Width		
CWDM channels	> 13 nm	
Upgrade ("UG") channel	1263.5-1437.5 nm	
Insertion Loss	max ¹	typical ²
CWDM channels	< 3.6 dB	2.0 dB
UG port	< 1.2 dB	0.9 dB
Isolation		
CWDM adjacent channel	> 30 dB	
CWDM non-adjacent channel	> 40 dB	
CWDM channels at Ug port	> 30 dB (Demux), > 15 dB (Mux)	
UG channel at CWDM ports	> 30 dB (Demux), > 15 dB (Mux)	
Isolation spectral range	1260 nm to 1620nm	
Polarization Dependent Loss	< 0.2 dB	

Notes:

1. Max. insertion loss over channel bandwidth, valid over full operating temperature range and all states of polarization with optical connectors. The typical connector loss is 0.4 dB for a pair of connectors
2. Typical insertion loss is defined as typical value over channel bandwidth, full operating temperature range and all states of polarization including optical connectors. Typical values have been derived with statistical methods from actual production data to reflect the majority of cases.

NETWORK CUBE
 > CWDM-MUX-8+UG Module

C-1678-Rev. C

Package Dimensions and Front Plate design

Logical setup:

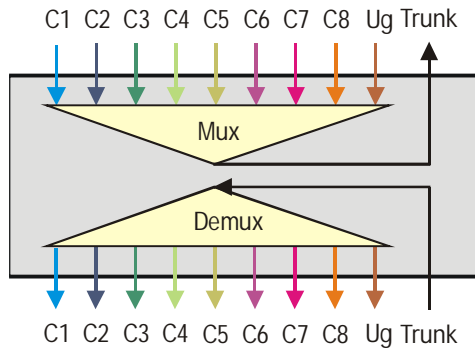

Connection Scheme:

- The module contains the adapters for one multiplexer (C1-C8, Ug) at the top and one demultiplexer (C1-C8, Ug) at the bottom.
- The channels are marked with “1470”, “1490”, “1510”, “1530”, “1550”, “1570”, “1590” and “1610” corresponding to the 8 corresponding transceiver wavelengths, respectively as “Ug” for the upgrade port.
- The common ports are marked as “Trunk”.

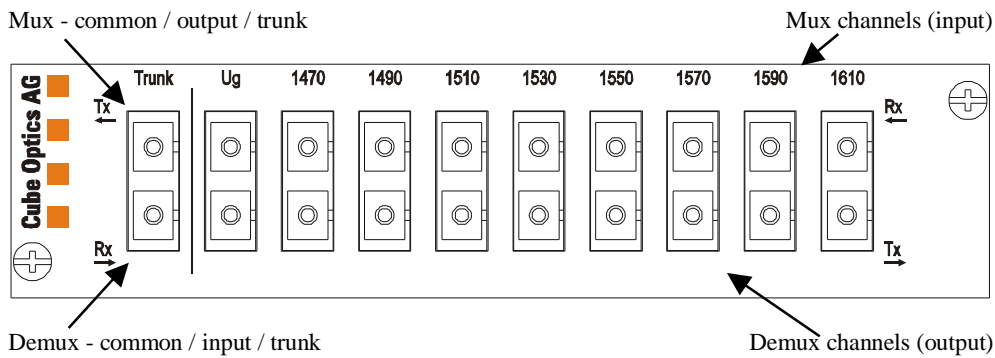

Please, note that the actual layout depends on the chosen connector type as well as other factors. However, the principal scheme stays the same.

Layout and dimensions (see also next page)

- Width: 166 / 182 mm
- Height: 25.75 / 44 mm
- Depth: 118.5 / 125.2 mm
- The color of the module is light gray
- All fonts and labels are printed in black.



NETWORK CUBE
 > CWDM-MUX-8+Ug Module

C-1678-Rev. C

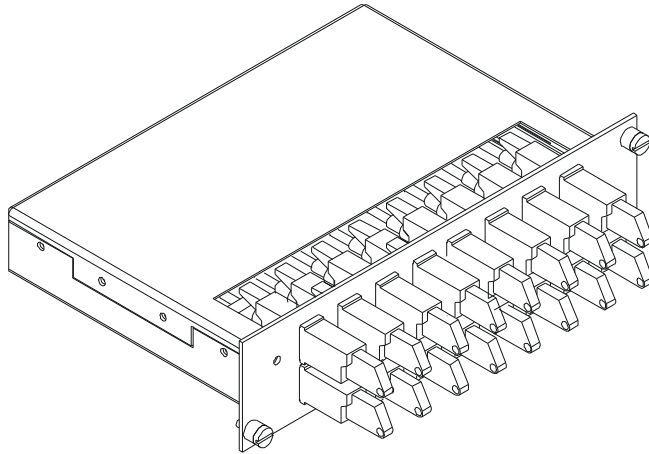

Please, note that the drawings shown here only show the dimensions and do not the specific configuration of the module!

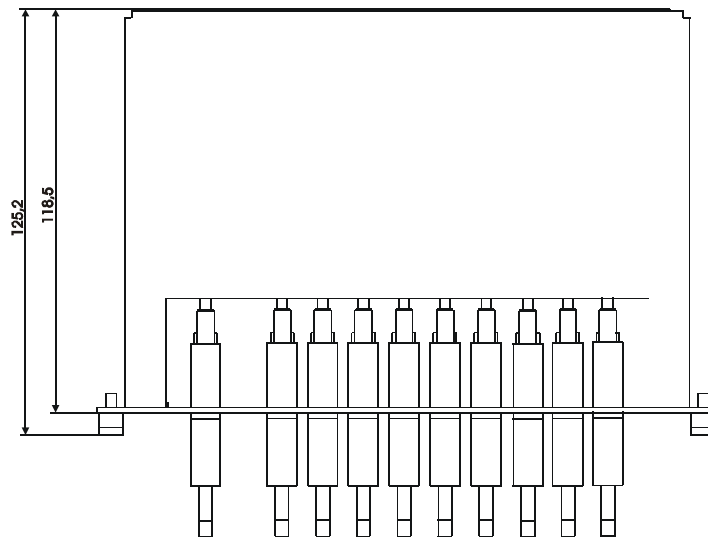
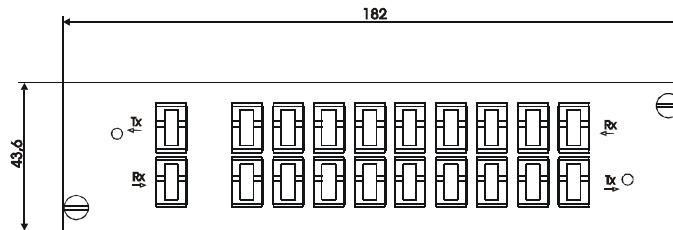

Corporate Office:
 Cube Optics AG
 Robert-Koch-Strasse 30
 55129 Mainz
 Germany

Fon: +49-6131-69851-0
 Fax: +49-6131-69851-79
 e.mail: sales@cubeoptics.com

www.cubeoptics.com