



NETWORK CUBE

> CWDM-MUX-4+Exp+1310 Module

C-1706-Rev. A

Product Description

- CWDM module for integration in 1 slot of the CUBO NETWORK CUBE WDM-Modular-Shell.
- The module contains 2 pieces of 4 channel + express+1310 CWDM multiplexers (one mux, one demux)
- CWDM multiplexers to mux and demux 4 channels 1471, 1491, 1591 and 1611; these correspond to the transceiver wavelengths from 1470 to 1610 nm
- The Express port may either be used as upgrade for up to 4 further CWDM channels (1511-1571) or as upgrade for one additional “broadband” (1504.5- 1577.5 nm) channel. Typical applications for the Express port: 10G XFP transceivers, standard FP laser , OTDR channel.
- The 1310 WDMs multiplex, respectively demultiplex the 1310nm from the 1550nm band.
- The CWDM multiplexers are compliant with the ITU G.694.2 standard and Telcordia GR1221 (former Bellcore) standard and are designed to meet NEBS level 3
- The sub-system interoperates with any router, switch, DSLAM, SFP and GBIC, which supports the CWDM ITU G.694.2 standard
- Front panel is equipped with adapters according to customer choice (see below).

■ Product Description: NETWORK CUBE CWDM-MUX-4+Exp+1310 Module

■ Product Code: C-1706

■ Connector Code: -XY (choose from table below)

■ Revision Level: -Rev.A

(X) Common ports	Code
(Y) CWDM channel ports	
SC/PC	1
FC/PC	2
SC/APC	3
FC/APC	4
LC/PC	5
MU/PC	6
E2000	7
E2000/HRL	8
ST/PC	9

Example Order Code: C-1706-11-Rev.A for a module with SC/PC connectors on all ports

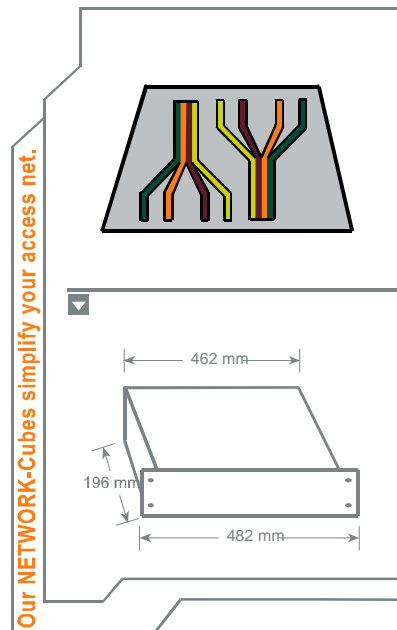

Our NETWORK-Cubes simplify your access net.

Revision History

No.	Description	Date	Created by	Approved by
A	Initial release	25.03.06	Thomas Paatzsch	
A	Reduced Insertion Loss	08.04.08	Thomas Paatzsch	
A	Included typical insertion loss value	26.01.10	Islah Touhtouh	
B				

NETWORK CUBE

> CWDM-MUX-4+Exp+1310 Module

C-1706-Rev. A

General Specifications

Operating Temperature	+0°C to +70°C	
Storage Temperature	-40°C to +80°C	
Max. optical Power	< 250 mW	
Package Dimensions	Width: 166 / 182 mm, Height: 25.75 / 44 mm, Depth: 118.5 / 125.2 mm	
Fiber Type	SMF-28 compatible	Ø 9 / 125 / 250µm
Optical Adapters	as defined by customer via order code	

Optical Performance of each of the 2 Multiplexers (1 mux, 1 demux)

Operating Channels	C1=1471 C2=1491 C3=1591 C4=1611	
CWDM [nm]		
Express [nm]	Exp = 1511 - 1571	
WWDM [nm]	W = 1310	
Channel Width		
CWDM channels	> 13 nm	
Express ("Exp") channel	1504.5-1577.5 nm	
WWDM channel	+/- 50 nm	
Insertion Loss	max ¹	typical ²
CWDM channels	< 2.5 dB	1.7 dB
Express ("Exp") channel	< 2.5 dB	1.4 dB
WWDM channel	< 1.6 dB	1.2 dB
Isolation		
CWDM adjacent channel	> 30 dB	
CWDM non-adjacent channel	> 40 dB	
CWDM channels at Exp port	> 28 dB	
Exp channel at CWDM ports	> 30 dB	
Exp, CWDM ch's at WWDM port	> 45 dB (Demux), > 15 dB (Mux)	
WWDM ch's at Exp, CWDM port	> 45 dB (Demux), > 15 dB (Mux)	
Isolation spectral range	1260 nm to 1620nm	

Notes:

1. Max. insertion loss over channel bandwidth, valid over full operating temperature range and all states of polarization with optical connectors. The typical connector loss is 0.4 dB for a pair of connectors.
2. Typical insertion loss is defined as typical value over channel bandwidth, full operating temperature range and methods from actual production data to reflect the majority of cases.

NETWORK CUBE
 > CWDM-MUX-4+Exp+1310 Module

C-1706-Rev. A

Package Dimensions and Front Plate design

Logical setup:

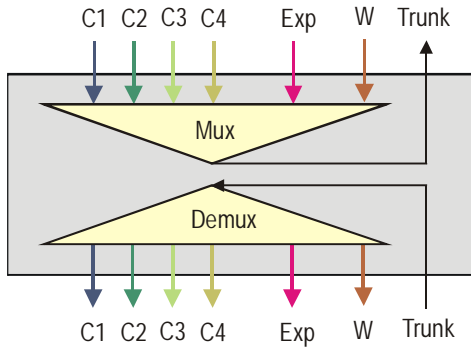

Connection Scheme:

- The module contains the adapters for one multiplexer (C1-C4, Exp, W) on the top and one demultiplexer (C1-C4, Exp, W) on the bottom.
- The channels are marked with “1470”, “1490”, “1590” and “1610” corresponding to the 4 corresponding transceiver wavelengths, respectively as “exp” for the express port and as “1310” for the WWDM port.
- The common ports are marked as “Trunk”.

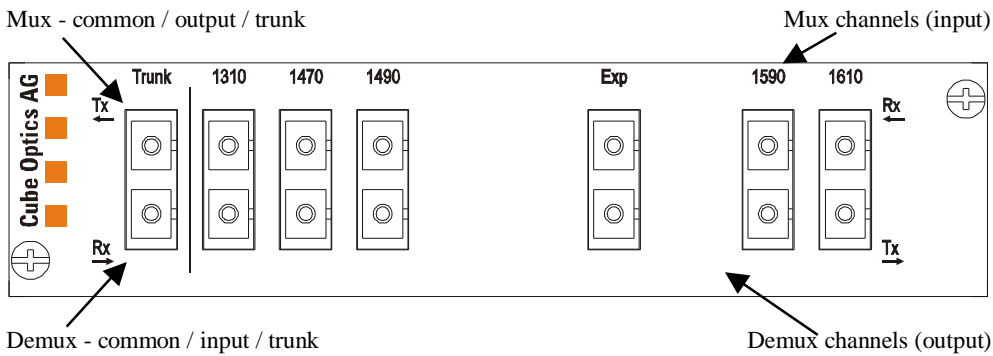

Please, note that the actual layout depends on the chosen connector type as well as other factors. However, the principal scheme stays the same.

Layout and dimensions (see also next page)

- Width: 166 / 182 mm
- Height: 25.75 / 44 mm
- Depth: 118.5 / 125.2 mm
- The color of the module is light gray
- All fonts and labels are printed in black.

NETWORK CUBE
 > CWDM-MUX-4+Exp+1310 Module

C-1706-Rev. A

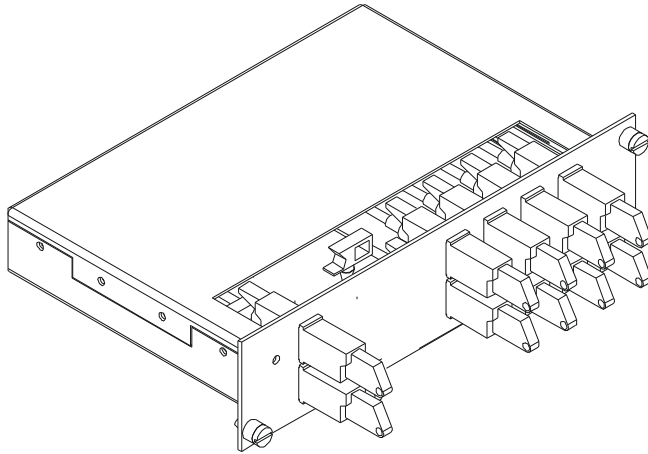

Please, note that the drawings shown here only show the dimensions and do not the specific configuration of the module!

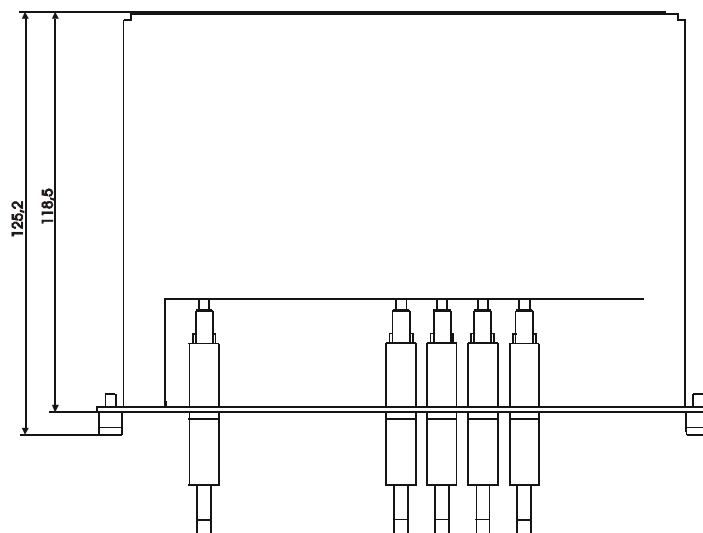
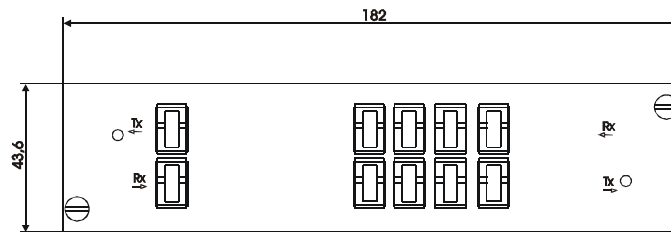

Corporate Office:
 Cube Optics AG
 Robert-Koch-Strasse 30
 55129 Mainz
 Germany

Fon: +49-6131-69851-0
 Fax: +49-6131-69851-79
 e.mail: sales@cubeoptics.com

www.cubeoptics.com