

# NETWORK-CUBE > DWDM MUX-8 Unit

C-1754-Rev. D

## Product Description

- Passive DWDM System for 19" rack type installation (1 HU)
- The module contains 2 pieces of 8 channel DWDM multiplexers (1 mux + 1 demux)
- DWDM multiplexer to mux and demux 8 DWDM channels in the C or L-band.
- The DWDM multiplexers are compliant with ITU-T G.694.1 and Telcordia GR1221 (former Bellcore) standards and are designed to meet NEBS level 3
- The sub-system interoperates with any router, switch, DSLAM, SFP and GBIC, which supports the DWDM ITU standard
- The systems comprise fixed (not exchangeable) modules
- The fixed front panel is equipped with adapters according to customer choice (see below)

- Product Description: NETWORK CUBE DWDM-MUX-8 Unit
- Product Code: C-1754
- Channel Code: -NN (first ITU channel number)
- Connector Code: -XY (choose from table below)
- Revision Level: -Rev.D

(X) Common ports	(Y) DWDM channel ports	Code
SC/PC		1
FC/PC		2
SC/APC		3
FC/APC		4
LC/PC		5
MU/PC		6
E2000		7
E2000/HRL		8
ST/PC		9

Example Order Code: C-1754-21-55-Rev.D for a system with ITU channels C21-C28 and LC/PC connectors on all ports.

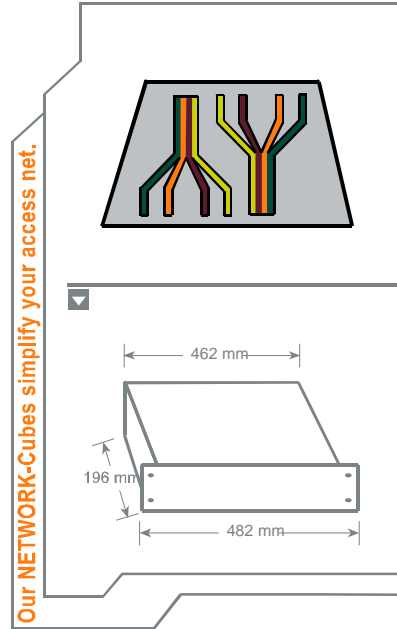

Our NETWORK-Cubes simplify your access net.

No.	Description	Date	Created by	Approved by
A	Initial release	14.09.06	Thomas Paatzsch	
B	Integrated Channel plan	12.10.06	Thomas Paatzsch	
C	Reduced insertion loss	31.10.06	Thomas Paatzsch	
D	Link Loss	04.12.07	Carsten Marheine	
D	Included typical insertion and link loss value	12.03.10	Islah Touhtouh	

## NETWORK CUBE

### > DWDM-MUX-8 Unit

C-1754-Rev. D

#### General Specifications

Operating Temperature	-5°C to +70°C	
Storage Temperature	-40°C to +85°C	
Max. optical Power	< 300 mW	
Optical Adapters		
Trunk (Dx Input / Mx Output)	According to customer's choice, to be selected with order code	
DWDM Channel Ports	According to customer's choice, to be selected with order code	

#### Optical Performance of the DWDM Mx/Dx

Operating Channels DWDM ports	Any ITU channels out of C- and L-Band, to be selected via order code	
Channel Spacing DWDM channels	100GHz	
Insertion Loss DWDM channels	max <sup>1</sup> < 3.4 dB	typical <sup>2</sup> 2.2 dB
Link Loss (mux+demux) DWDM channels	max <sup>1</sup> < 4.7 dB	typical <sup>2</sup> 4.3 dB
Isolation	Mx	Dx
DWDM adjacent channel	> 12 dB	> 25 dB
DWDM non-adjacent channel	> 12 dB	> 40 dB
Optical Return Loss	> 45 dB (for the component, also depends on selected connector type)	
Directivity	> 60 dB	
Polarization Dependent Loss	< 0.2 dB	

#### Notes:

1. Max. insertion loss over channel bandwidth, valid over full operating temperature range and all states of polarization with optical connectors. The typical connector loss is 0.4 dB for a connector pair
2. Typical insertion and link loss is defined as typical value over channel bandwidth, full operating temperature range and methods from actual production data to reflect the majority of cases.

# NETWORK CUBE

## > DWDM-MUX-8 Unit

C-1754-Rev. D

### Package Dimensions and Front Plate design

Logical setup:

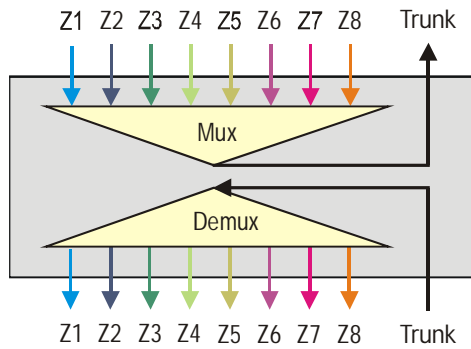

The descriptions Z1-Z8 correspond to above specified DWDM channel numbers

### Connection Scheme:

- The module contains the adapters for one multiplexer at the top and one demultiplexer at the bottom.
- The channels are marked with above specified ITU channel numbers (e.g. C24, C25, ...).
- The common ports are marked as "Trunk".

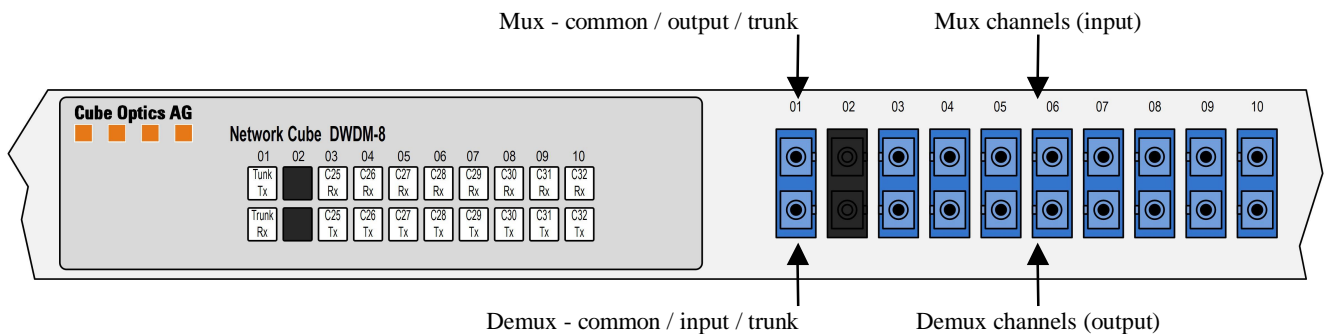

Please, note that above layout refers to a DWDM-MUX-8 Unit and is taken only as example. The actual layout of the unit described in this document depends on a number of factors such as channel number and connector type. However, the principal scheme will stay the same.

### Layout and dimensions (see also next page)

- Width: 483 mm (19"), 532 mm (ETSI)
- Height: 43.6 mm (1.732") / 1HU
- Depth: 125 / 214.2 mm (without / with patch cord shelf)
- The color of the module is light gray
- All fonts and labels are printed in black.

NETWORK-CUBE  
> DWDM-MUX-8 Unit

C-1754-Rev. D

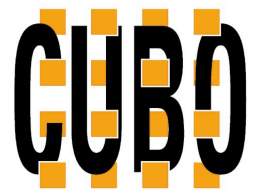

Please, note that the drawings shown here only show the dimensions and do not the specific configuration of the module!

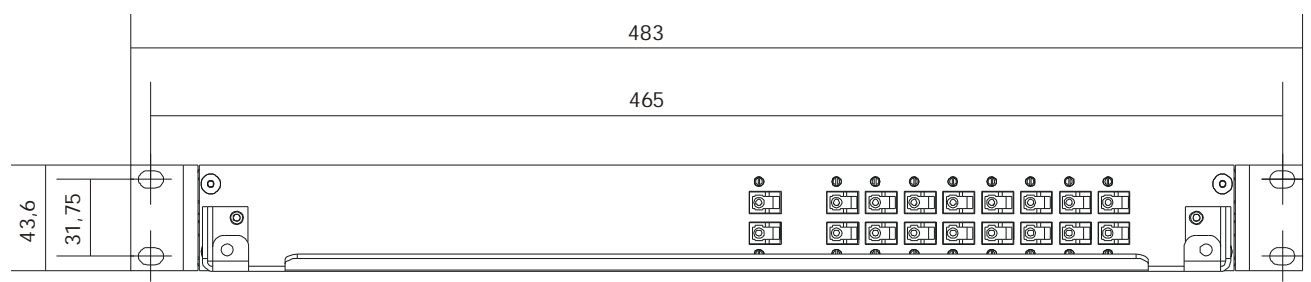
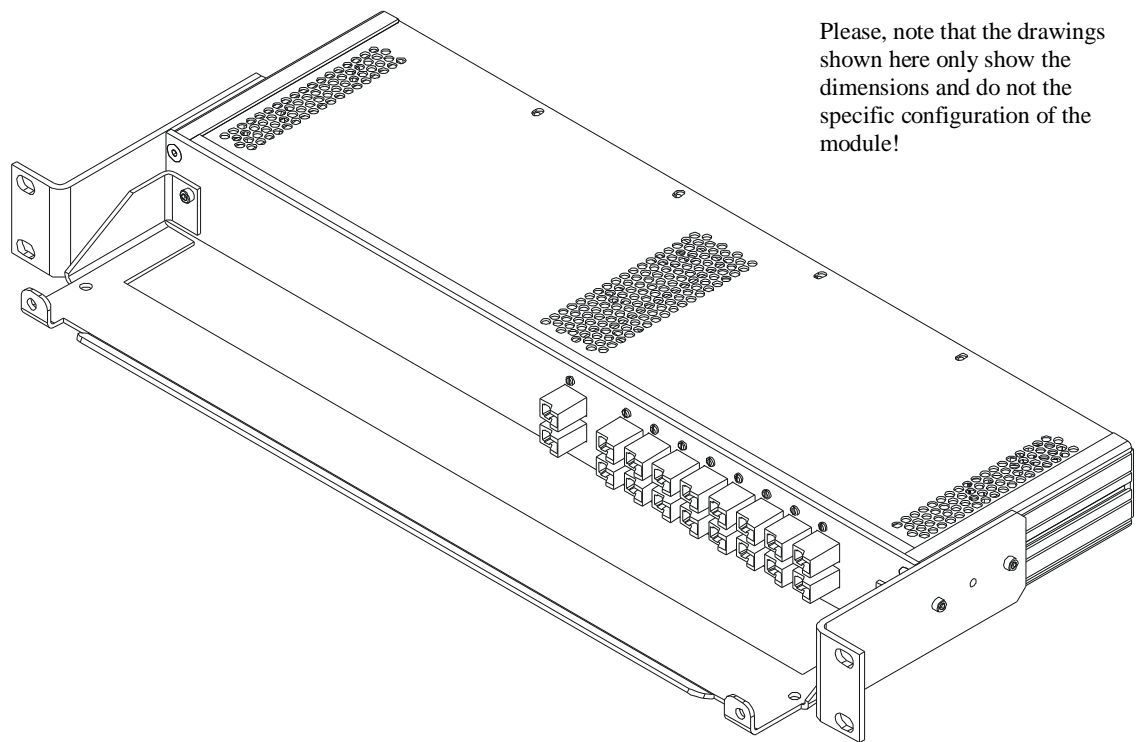

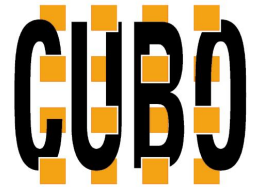

ITU Grid Standard Wavelength Reference Table

Channel Number	Frequency (GHz)	Wavelength (nm)	Channel Number	Frequency (GHz)	Wavelength (nm)
C21	192100	1560.61	C41	194100	1544.53
C22	192200	1559.79	C42	194200	1543.73
C23	192300	1558.98	C43	194300	1542.94
C24	192400	1558.17	C44	194400	1542.14
C25	192500	1557.36	C45	194500	1541.35
C26	192600	1556.55	C46	194600	1540.56
C27	192700	1555.75	C47	194700	1539.77
C28	192800	1554.94	C48	194800	1538.98
C29	192900	1554.13	C49	194900	1538.19
C30	193000	1553.33	C50	195000	1537.40
C31	193100	1552.52	C51	195100	1536.61
C32	193200	1551.72	C52	195200	1535.82
C33	193300	1550.92	C53	195300	1535.04
C34	193400	1550.12	C54	195400	1534.25
C35	193500	1549.32	C55	195500	1533.47
C36	193600	1548.51	C56	195600	1532.68
C37	193700	1547.72	C57	195700	1531.90
C38	193800	1546.92	C58	195800	1531.12
C39	193900	1546.12	C59	195900	1530.33
C40	194000	1545.32	C60	196000	1529.55

Corporate Office:  
Cube Optics AG  
Robert-Koch-Str. 30  
55129 Mainz  
Germany

Fon: +49-6131-69851-0  
Fax: +49-6131-69851-79  
e.mail: [info@cubeoptics.com](mailto:info@cubeoptics.com)

[www.cubeoptics.com](http://www.cubeoptics.com)